

**S100 Serial UPS(1-10K)**

**USER MANUAL**

# Introduction

Thanks for choosing S100 Series UPS products! S100 is an double conversion online UPS with sine wave output, the product powered by DSP digital control technology and high frequency PWM Inverter technology, provides comprehensive protection to mission critical equipment, such as computer, communication equipment, medical equipment etc. from loss of data or even hardware damage by power blackout or other kind of power quality issues.

This manual introduce S100 Series UPS functions and features, guidance to installation operation, maintenance and transportation information.

Please read this manual carefully and thoroughly before operation the UPS. The manual is offered when you purchase our product.

# Content

Chapter 1 Safety Instruction.....	3
Chapter 2 Product introduction.....	4
2.1 Product introduction.....	4
2.2 Mode type.....	4
2.3 UPS Outlook.....	4
Chapter 3 Installation.....	8
3.1 Product inspection.....	8
3.2 Installation.....	8
3.3 Wiring .....	8
Chapter 4 Panel & Operation Guide.....	13
4.1 Front panel.....	13
4.2 UPS Working Mode.....	16
4.3 Operation.....	17
Chapter 5 Maintenance.....	20
5.1 Routine Maintain .....	20
5.2 Battery maintain.....	20
Chapter 6 Trouble shooting.....	21
6.1 LED Panel Warning and Fault Information.....	21
6.2 LCD Warning and Fault Code.....	21
Chapter 7 Specification.....	23
7.1 Electrical.....	23
7.2 Mechanical.....	24
7.3 Environmental.....	24
7.4 EMC & Safety Regulation.....	24
Warranty.....	25

# Chapter 1 Safety Instruction

This manual contains important instructions that you should follow during installation and maintenance of the UPS and batteries. Please read all instructions before operating the equipment and save this manual for future reference.

Strictly follow the Safety instruction for equipment installation, operation and maintenance, inappropriate operation may cause injury to personnel and equipment. manufacturer assume no responsibility for violation of operation.

## **Danger**

- This UPS contains LETHAL VOLTAGES. All repairs and service should be performed by **AUTHORIZED SERVICE PERSONNEL ONLY. There are NO USER SERVICEABLE PARTS** inside the UPS.
- CUT OFF all power supply before any installation and manipulation of power wiring.
- Reverse connection polarity , short-circuit of battery terminal may cause harmful high current , or even fire, make sure proper connect battery.
- Cable with sufficient current rating should be used for wiring, secure fixation and proper insulation are all required to avoid fire accident cause by wired overheat or short-circuit.

## **Warning**

- This UPS contains its own energy source (batteries). The UPS output may carry live voltage even when the UPS is not connected to an AC supply.
- To reduce the risk of fire or electric shock, install this UPS in a temperature and humidity controlled, indoor environment, free of conductive contaminants. Ambient temperature must not exceed 40°C (104°F). Do not operate near water or excessive humidity (90% maximum).
- To reduce the risk of fire, connect only to a circuit provided with branch circuit over-current protection . Output overcurrent protection and disconnect switch must be provided by others.
- To comply with international standards and wiring regulations, the sum of the leakage current of the UPS and the total equipment connected to the output of this UPS must not have an earth leakage current greater than 3.5 milliamperes.
- If installing optional rack-mount Battery Pack, install the Battery Pack directly below the UPS so that all wiring between the cabinets is installed behind the front covers and is inaccessible to users.

## **Caution**

- Batteries can present a risk of electrical shock or burn from high short-circuit current. Observe proper precautions. Servicing should be performed by qualified service personnel knowledgeable of batteries and required precautions. Keep unauthorized personnel away from batteries.
- Proper disposal of batteries is required. Refer to your local codes for disposal requirements.
- Never dispose of batteries in a fire. Batteries may explode when exposed to flame.
- In the event of fire occurring in the vicinity, please use dry powder fire extinguishers. The use of liquid fire extinguishing agents may cause electric shock.

# Chapter 2 Product introduction

## 2.1 Product introduction

S100 Series Uninterruptible Power Supply(UPS) is a new generation product incorporating double-converter, Single-phase input and Single-phase output. With high efficiency and reliability, it provides user's equipment with safe, high-quality AC power supply. Designed with the small dimension, thiS100 Series of UPS is convenient for operation, especially fit for the basic equipment in areas of finance, communication, government, traffic, manufacture, education and so on.

## 2.2 Mode type

S100 Series UPS mode type shown below.

(x)K [S] [R]

(x) Means capacity of UPS, 1, 2, 3,6,10kVA product for this manual .

[S] With S means Long Back Time Model, UPS can connect with external batteries for extra long backup time. And without S means UPS is standard backup time type.

[R] With R means Rack mounted, without R is Tower mounted.

Model		Model	Remark
Standard	1kVA	SIK	With a 1.5A internal charger and 2 batteries
	2kVA	S2K	With a 1.5A internal charger and 4 batteries
	3kVA	S3K	With a 1.5A internal charger and 6 batteries
	6kVA	S6K	With a 1.5A internal charger and 12 batteries
Long Backup Time	1kVA	S1KS	With a 6A internal charger and external battery
	2kVA	S2KS	With a 6A internal charger and external battery
	3kVA	S3KS	With a 6A internal charger and external battery
	6kVA	S6KS	With a 4.5A internal charger and external battery
	10kVA	S10KS	With a 4.5A internal charger and external battery

Note: For 2/3K Rack UPS, Batteries not installed, but a battery Pack must be configured. For 6/10K Rack UPS, Batteries not installed.

## 2.3 UPS Outlook

### 2.3.1 Front View

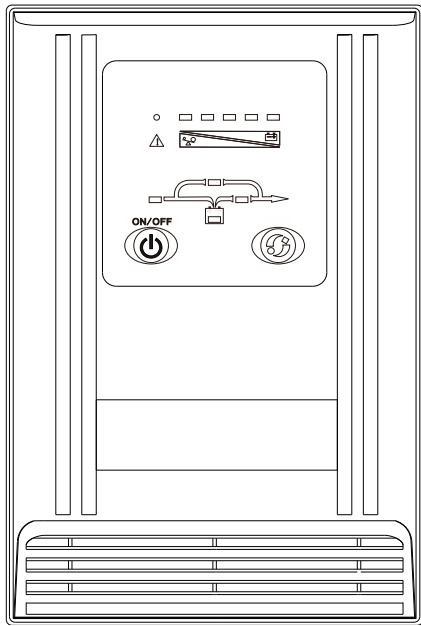

S1K(L)

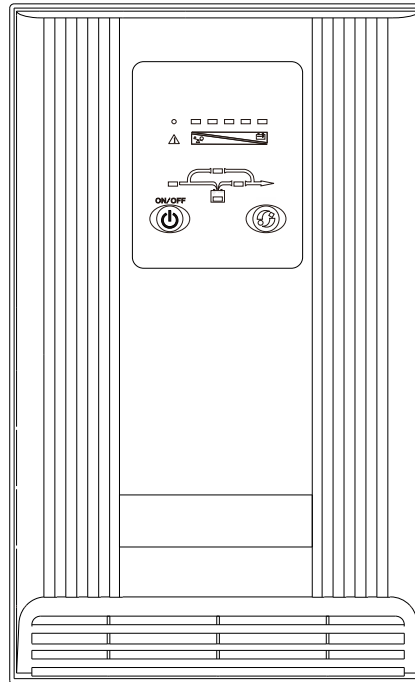

S2K(L)/S3K(L) /S6K(L)/S10K(L)

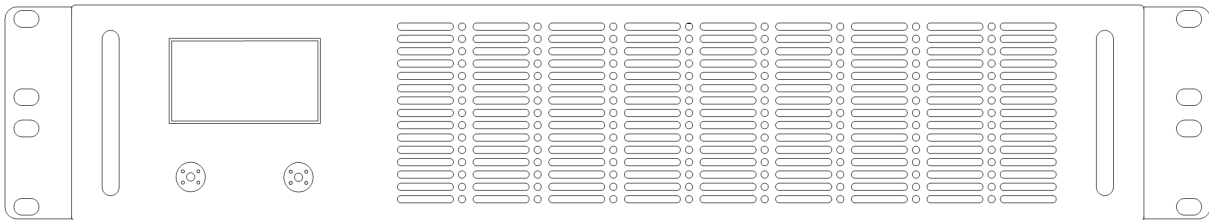

S1K(L)/S2K(L)/S3K(L) /S6K(L)/S10K(L) RACK UPS

### 2.3.2 Rear View

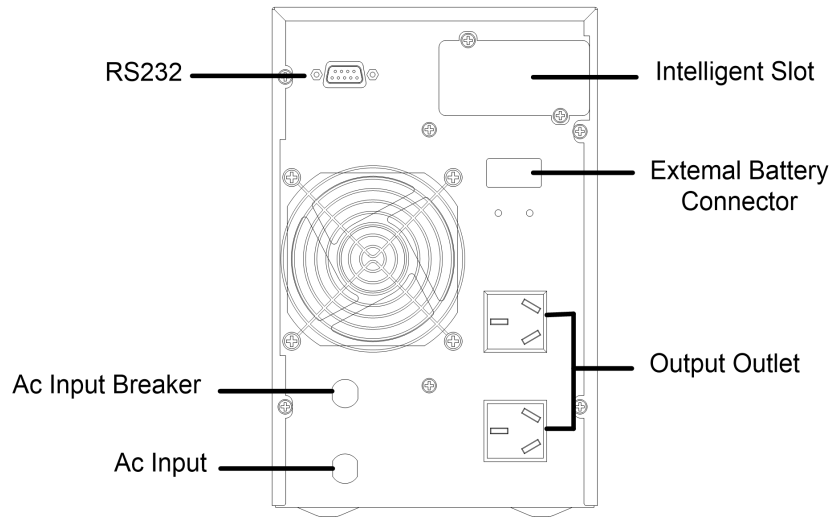

S1KS Rear Panel

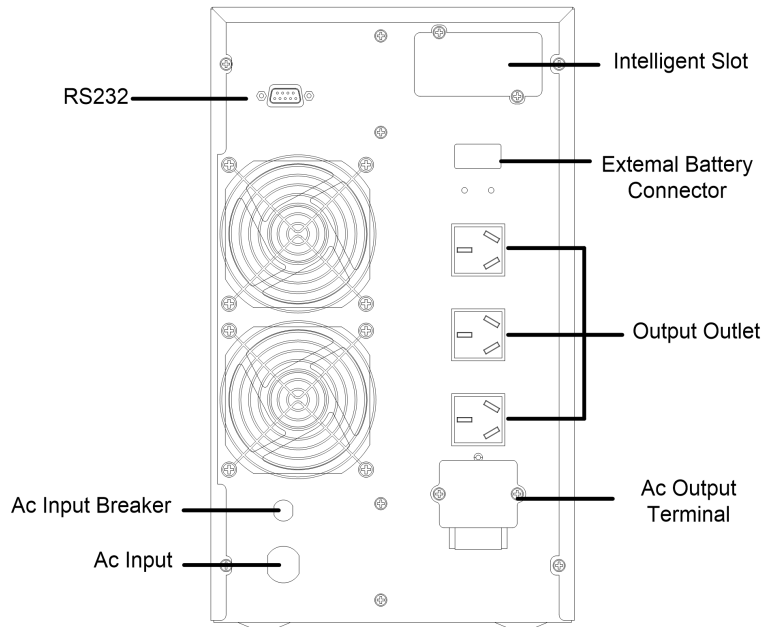

S2/3KS Rear Panel

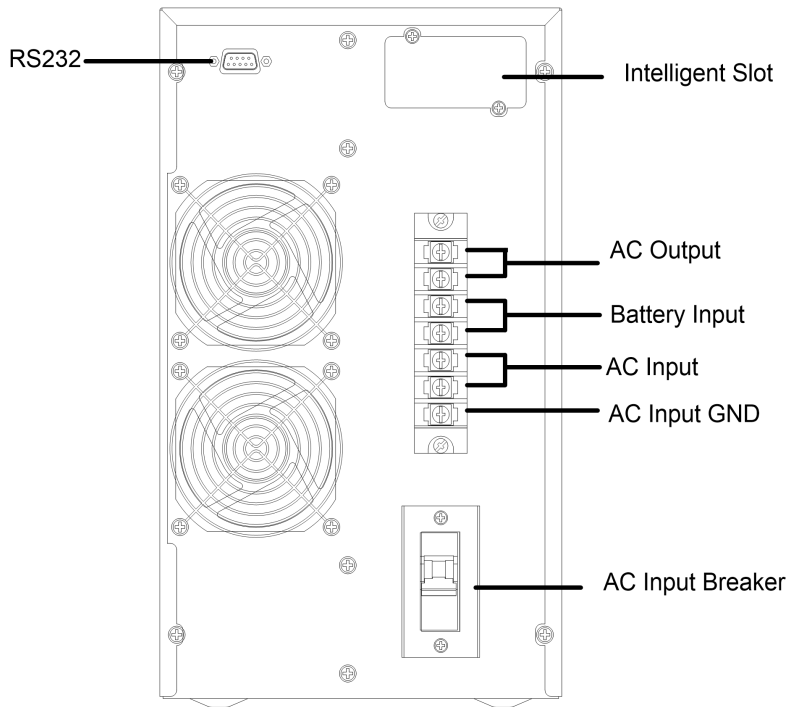

S6/10KS Rear Panel

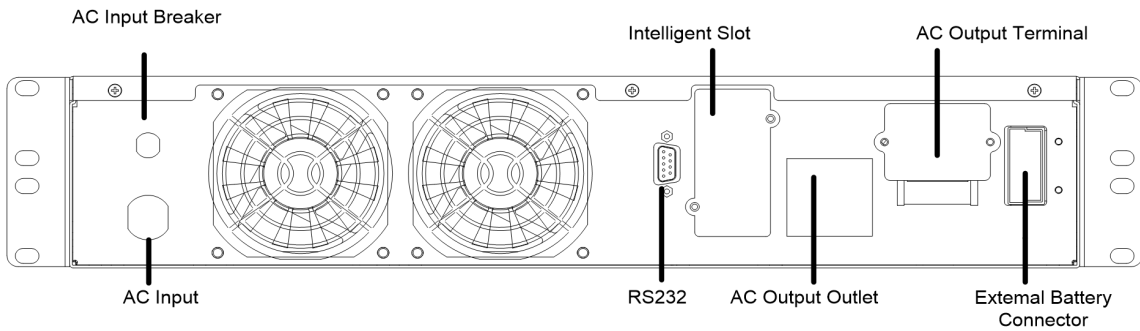

S1/2/3KS RACK UPS Rear Panel

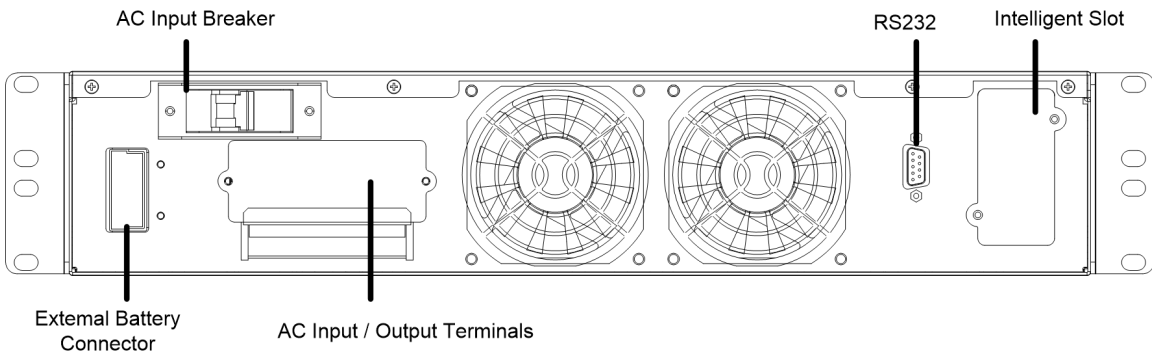

S6/10KS RACK UPS Rear Panel

**Note:**

1. Output sockets type and quantity may vary for different countries
2. Above all are long backup type UPS, for standard backup UPS, there are no External battery Connectors.
3. The Rear Panel, according to local requirements, may be slightly different for different countries or regions.

# Chapter 3 Installation

## 3.1 Product inspection

Unpacking the cabinet, Open the outer carton and remove the accessories packaged in the cabinet

Carefully lift the cabinet out of the outer carton. Note the UPS mode with internal battery is heavy, two person or proper tools should be used to take the equipment out

Inspection equipment

Checking accessories according to below of shipping list.

Please contact the distributor if damages in transportation found or lacks of random accessories are found.

UPS accessories of shipping list:

Mode	Accessory	Quantity	Unit
Standard	User manual	1	Pcs
Long backup time (1-3KS)	User manual	1	Pcs
	External battery cable	1	Pcs
Long backup time (6-10KS)	User manual	1	Pcs

## 3.2 Installation

Because of heavy weight, a steady space needs to install the UPS. Cool, good ventilation, less humidity and dust is required for safe and reliable operation of the UPS

## 3.3 Wiring

### NOTE:

Do not apply power to the UPS until installation is totally completed.

Do not make unauthorized changes to the UPS; otherwise, damage may occur to your equipment and void your warranty.

### 3.2.1 Input Wiring

1, 2, 3K (220V/230V/240V) Model comes with input cable with plug. Plug the input cable to appropriate mains supply socket .

1, 2, 3K (110V/120V/127V) Model and 6, 10kVA model use fixed terminal block for input

wiring. a ring terminal is recommend for reliable wiring.

Note the voltage and current rating of the product. Refer to below table for input wiring

Model	Nominal Input Voltage	Rated Input Current	Input Cable AWG/Cross-section Area
1kVA(HV)	220V/230V/240V	5.5A	14AWG/2mm <sup>2</sup>
2kVA(HV)	220V/230V/240V	11A	14AWG/2mm <sup>2</sup>
3kVA(HV)	220V/230V/240V	16A	14AWG/2mm <sup>2</sup>
1kVA(LV)	110V/120V/127V	10A	14AWG/2mm <sup>2</sup>
2kVA(LV)	110V/120V/127V	22A	12AWG/4mm <sup>2</sup>
3kVA(LV)	110V/120V/127V	32A	10AWG/5mm <sup>2</sup>
6KVA	220V/230V/240V	32A	10AWG/5mm <sup>2</sup>
10KVA	220V/230V/240V	55A	8AWG/8mm <sup>2</sup>

Event internal over current protection breaker is embedded in the product, external switchable circuit break should be installed upstream of the UPS product for safe installation and maintenance of product.

### 3.2.2 Output Wiring

The input of the equipment needs to be protected by UPS should connect to the UPS output

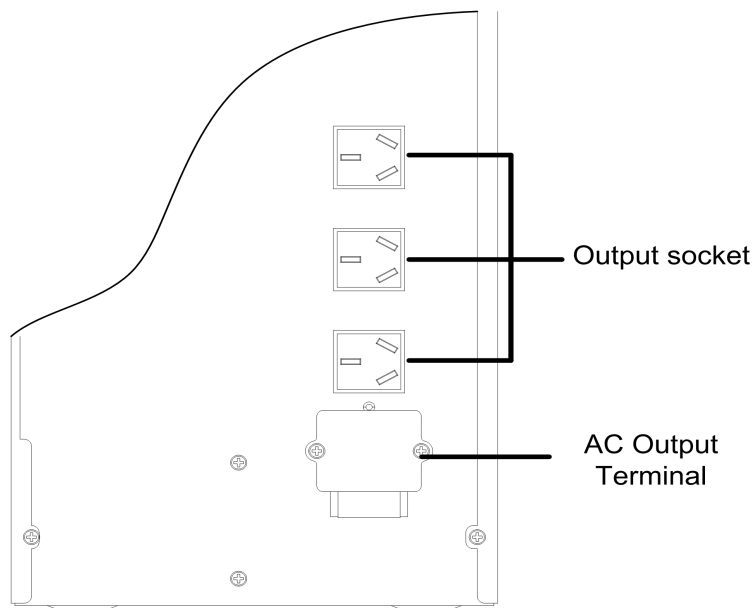

Output socket and terminal block are available for output connection from UPS, with refer to figure in section 2.3.2:

Rating	Mode	Quantity of output socket	Output terminal block
1kVA	S1K / S1KS	2	NA
2kVA	S2K / S2KS	4	NA
3kVA	S3K / S3KS	3	Available
6kVA	S6K/S6KS	NA	Available
10kVA	S10K/S10KS	NA	Available

Please find rated output capacity of product, avoid overload and used wire with sufficient current rating, with refer to below table.

Model	Nominal Output Voltage	Rated output Current	Wire for terminal
1kVA(HV)	220V/230V/240V	5A	>14AWG/2mm <sup>2</sup>
2kVA(HV)	220V/230V/240V	10A	>14AWG/2mm <sup>2</sup>
3kVA(HV)	220V/230V/240V	15A	>14AWG/2mm <sup>2</sup>
1kVA(LV)	110V/120V/127V	10A	>14AWG/2mm <sup>2</sup>
2kVA(LV)	110V/120V/127V	20A	>12AWG/4mm <sup>2</sup>
3kVA(LV)	110V/120V/127V	30A	>10AWG/5mm <sup>2</sup>
6KVA	220V/230V/240V	30A	>10AWG/5mm <sup>2</sup>
10KVA	220V/230V/240V	46A	>8AWG/8mm <sup>2</sup>

Procedure for output wiring:

1. Plug the AC input core of the equipment needs UPS protection to the output socket of the UPS.
2. To connect more equipment than available output socket number, please use extension core, connect to the output socket or output terminal block. mind the total consumption current must not exceed rated current capacity of the product.
3. The output terminal is protected by a cover, uncover the terminal, use appropriate connecting terminal, prepare well the wire.
4. Fix the prepared wired to the terminal block securely, find the label of terminal for polarity of

the wiring.

### 3.2.3 External Battery Cable

Connection of external **ABSOLUTELY CRITICAL**. Any mistake may result in serious injury of electric shock and fire, damage of product. below steps must be strictly followed :

- The external battery bank must have a cutoff device, like circuit breaker or switch with fuses.
- **TURN OFF** the cut off device , make sure no harmful voltage can be touch on the terminal to be connect.
- Use only battery bank of correct voltage , check the product rating label for correct information.
- Choose Wire with sufficient current rated , prepared well the terminal
- CHECK THE POLARTIY of battery bank , fix the first end of the wire to the battery bank with color and clear label for distinguish the wire polarity.
- Securely Plug / Fix the other end of the cable to UPS
- Check the polarity of the wiring and fastness of the connection
- Powered the UPS by turning on the cutoff device device

Model	Nominal Battery Voltage	Rated Battery Current	Connection Wire
1KS (HV/LV)	36V	30A	>10AWG/5mm <sup>2</sup>
2KS (HV/LV)	72V	30A	>10AWG/5mm <sup>2</sup>
3KS (HV/LV)	96V	30A	>10AWG/5mm <sup>2</sup>
6KS	192V	40A	>10AWG/5mm <sup>2</sup>
10KS-192B	192V	60A	> 8AWG/8mm <sup>2</sup>
10KS-240B	240V	50A	

### 3.2.4 Communication Cable (optional)

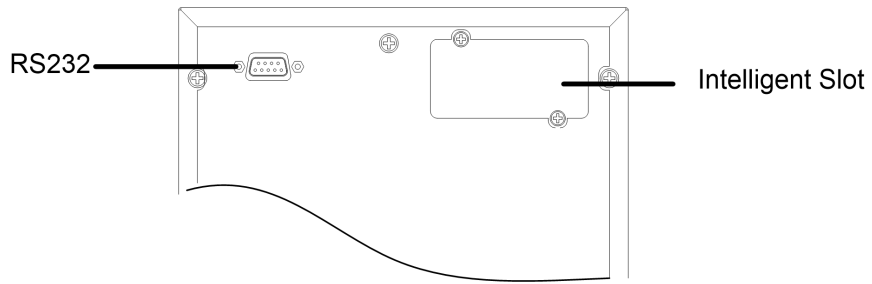

RS232 : Connect UPS computer Interface (RS232) and monitor equipment through communication cable. consult with distributor for communication protocol .

Intelligent slot connection (optional), The intelligent slot is used for extend SNMP card, Modbus Card, AS400 card, refer to the card user manual for application

# Chapter 4 Panel & Operation Guide

## 4.1 Front panel

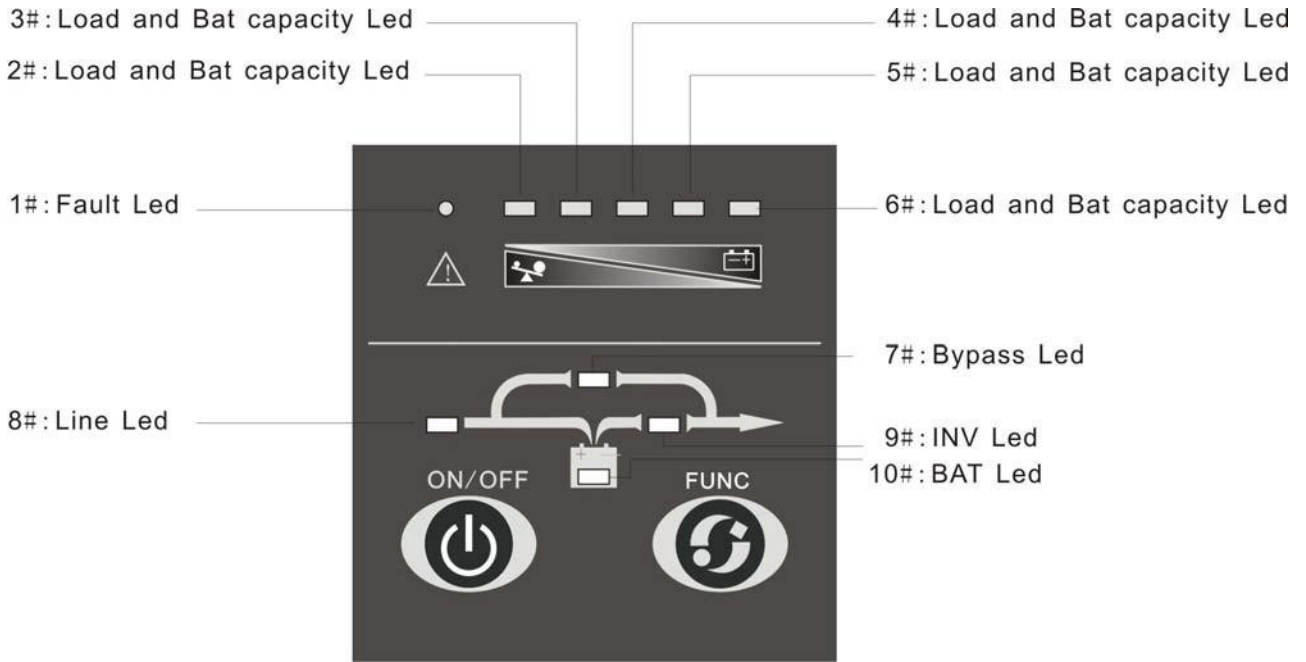

Led Panel

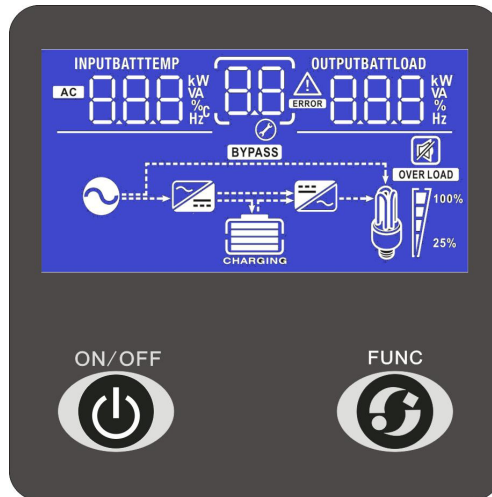

LCD Panel

### 4.1.1 ON/OFF Button

Turn on : by pressing the ON/OFF button more than one second, the UPS system is turned on

Turn off : by pressing this button more than 1second to turn off the UPS system  
whenever the UPS run under the normal mode/battery mode

#### 4.1.2 Function button

Battery self-test:

when the UPS run in normal mode, press the button for more then 2 seconds can start the battery self-test

Buzzer Mute function:

in battery mode: In battery mode, when the buzzer beeps, pressing and holding the function button for 2 seconds can silence the buzzer. Press the button for more than 2 seconds again to resume the alarm function

the Buzzer Mute of the Function button is valid only in battery mode, and invalid for any other UPS alarm.







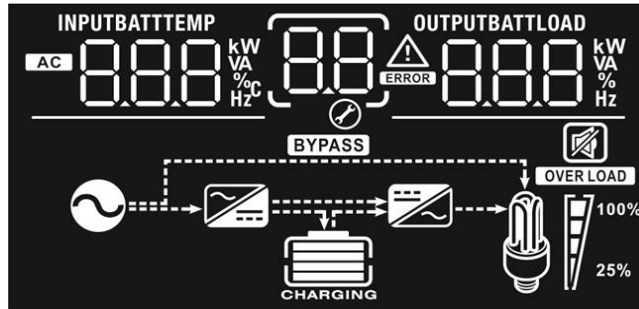

#### 4.1.3 Led indicator

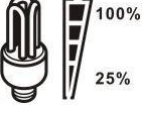
No.#	Indicator	Specification	Description
1#	Fault indicator	Red	When the indicator on, it shows the UPS in abnormal condition , Inverter output power off
2#	Alarm indicator	Yellow	When the indicator alarm, it show the UPS in abnormal condition, Inverter output without interruption
3#	Load/battery capacity indicator	Green	In Normal mode ,the percentage of load capacity is 75~100%;the battery capacity level is 0~25%
4#	Load/battery capacity indicator	Green	In Normal mode ,the percentage of load capacity is 50~75%;the battery capacity level is 25~50%
5#	Load/battery capacity indicator	Green	In Normal mode ,the percentage of load capacity is 50~75%;the battery capacity level is 25~50%
6#	Load/battery capacity indicator	Green	In Normal mode ,the percentage of load capacity is 0~25%;the battery capacity level is 75~100%
7#	By pass indicator	Yellow	When the indicator on, it shows the UPS output bypass
8#	Utility power indicator	Green	When the indicator on, it shows that the utility power is normal. When the indicator blink ,it shows the utility power is abnormal. When the indicator off, the utility power off
9#	Inverter indicator	Green	When the indicator on ,it shows the UPS Inverter output
10#	Battery indicator	Yellow	When the indicator on, it shows the battery in normal condition, or the battery in abnormal condition

#### 4.14 LCD Display



con	Function description
<b>Input Source Information</b>	
<b>AC</b>	Indicates the AC input.
<b>INPUTBATT</b> 888 kW VA %C Hz	Indicate input voltage, input frequency, battery voltage
<b>Fault Information</b>	
	Indicates the warning and fault codes.  Warning:  flashing with warning code.
	Fault:  lighting with fault code
<b>Output Information</b>	
<b>OUTPUTBATTLOAD</b> 888 kW VA % Hz	Indicate output voltage, output frequency, load percent, load in VA, load in Watt.
<b>Battery Information</b>	
	Indicates battery level by 0-24%, 25-49%, 50-74% and 75-100% in battery mode and charging status in line mode.

Load Information				
	Indicates overload.			
	Indicates the load level by 0-24%, 25-50%, 50-74% and 75-100%.			
	0%~25%	25%~50%	50%~75%	75%~100%
				
Mode Operation Information				
	Indicates unit connects to the mains.			
	Indicates load is supplied by utility power.			
	Indicates the DC/AC Inverter circuit is working.			
Mute Operation				
	Indicates unit alarm is disabled.			

## 4.2 UPS Working Mode

### 4.2.1 Line mode

Turn on the UPS, if the Normal mode is normal, UPS will work in Normal mode and the indicator on the panel will be turned on.

If load capacity over 100%, the buzzer beeps to remind you overloaded that you must reduce unnecessary load until the UPS load capacity less than 100%.

If the battery blinks cyclically, it shows the UPS without battery or the battery voltage is too low. Then you should check if the battery is connected well

### 4.2.2 Battery mode

When there is no utility power, UPS will run in battery mode.

In the Battery mode, UPS will beep once every 4s. the user can silence the beep by the function key.

Please see the silence function.

If the battery capacity is very low, the UPS will beep once every 1S. It tells the user should take off the load as soon as possible.

If the line led blink, it means the utility power voltage or frequency is out of range, or the L, N is reversed or the Earth cable is not connected.

The user can test the backup function through cutoff the utility power input.

### **4.2.3 Bypass mode**

Through the software we can set the UPS working in bypass mode or not.

When the utility power is normal and don't turn on UPS, and UPS will working in the bypass mode.

Note: When UPS running in bypass mode, UPS has no backup function, because load power is supplied by the utility power directly.

## **4.3 Operation**

### **4.3.1 Turn on UPS**

Note: Although the battery has been fully charged in factory, it is suggested to turn on the UPS with utility power, refer to following contents, to charge the battery for the first time use to ensure enough back up time.

The operation of turning on the UPS contains: turning on with utility power and turn on without utility power

#### **Turning on with utility power**

Connect the mains input to the UPS, press and hold the ON/OFF button for more than one second until the buzzer beeps. At this point, the UPS begins to conduct self-test, with the load /battery capacity indicators on the front panel turned on and then off one after another. Seconds later, the Inverter indicator, the utility power indicator will turn on , meanwhile the UPS begins to operate under the Normal mode .If the utility power is abnormal, the UPS will work under the Battery mode.

#### **Turning on without utility power**

With no mains input to feed the UPS, press and hold the ON/OFF for than 2 seconds, the UPS

acknowledge with a buzzer beeps. In the power on process, the UPS has the same operation as if it is connected to utility power that the utility power indicator will not on, instead the battery indicator will on

#### **4.3.2 Turn off UPS**

The operation of powering down contains: Power down under Normal mode, power down under Battery mode

##### **Power down UPS under the Normal mode.**

Press and hold the ON/OFF button persistently for more than one second to power off UPS. If it is set up to work in bypass mode by monitoring software, the bypass indicator will be turned on to indicate that UPS is working in bypass mode. In order to cut off the output of the UPS, simply cut off the utility power. Finally, not any display is shown on the front panel and no output is available from the UPS outlets.

##### **Power down UPS under the Battery mode**

Press and hold the "ON/OFF" for more than one second to power down the UPS. At this point, UPS will start self-test and all the load /battery capacity indicators will be turned on and off one after another.

Meanwhile no display is shown on the front panel and no voltage output is available from the UPS.

#### **4.3.3 Battery self-test**

In UPS operation, user can manually initiate the battery self-test to check the battery condition. There are two methods to initiate the battery self-test.

##### **Through the function button**

In Normal mode, press the function button for more than 2 seconds until the buzzer beeps. At this point, the 7#~10#indicator blink cyclically, indicating that

UPS has transferred to battery mode and the battery has started self-test. The battery self-test will last for 10 seconds (it can also be set up by monitoring software). In the event of battery fault, UPS will transfer to Normal mode automatically.

##### **Through the monitoring software**

user can start battery self-test through monitoring software, refer to monitoring software for details.

#### 4.3.4 Buzzer Mute Operation

When UPS is on battery or bypass mode, UPS will warn with warning tone (Battery mode four seconds one tone; Bypass mode two minutes. You can disable or enable the warning tone manually.

Notes: Battery mode, only the four second once tone could be muted. Two ways to realize the function.

##### By function key

In the battery and bypass mode, push function key for about 2 seconds until you here a tone. If there is a warning tone, it will disable or enable the warning tone;

##### Through the Software

The user can use the software to configure this function.

#### 4.3.5 Led Panel led display and beep warning

(● : means light ★ : means blink ↑ : means: defined by others)

Index	UPS status		LED#										Warning tone	
			1	2	3	4	5	6	7	8	9	10		
1	Line mode	0%--30% Load						●		●	●		No	
2		31%--50% Load					●	●		●	●		No	
3		51%--70% Load				●	●	●		●	●		No	
4		71%--95% Load			●	●	●	●		●	●		No	
5		96%--105% Load		●	●	●	●	●		●	●		No	
6	Battery mode	0%--25% Load		●							●	●	Beep 1 every 1s	
7		26%--50% Load		●	●						●	●	Beep 1 every 4s	
8		51%--75% Load		●	●	●					●	●	Beep 1 every 4s	
9		76%--100% Load		●	●	●	●				●	●	Beep 1 every 4s	
10		100% Load		●	●	●	●	●			●	●	Beep 1 every 4s	
11	Bypass mode			↑	↑	↑	↑	●	●	●			Beep 1 every 2m	
12	Line mode overload to bypass		●	●	●	●	●	●	●	●			Beep	
13	Line is abnormal			↑	↑	↑	↑	●	↑	★	↑	↑	↑	
14	Battery mode overload, warning .		●	●							●	●	Beep 2 every 1s	
15	Battery mode overload, turnoff UPS		●	●									Beep	
16	Over temperature		●	●				●	↑	↑			Beep	
17	Inverter abnormal		●				●		↑	↑			Beep	
18	Bus abnormal		●			●			↑	↑			Beep	
19	Charger output is high		●		●				↑	↑			Beep	
20	Battery is abnormal		↑	↑	↑	↑	↑	●				★	↑	
21	L,N reversed or earth is not connected.			↑	↑	↑	↑	↑	●	↑	★		↑	Beep 1 every 2mins
22	Battery test			↑	↑	↑	↑	↑					Light circularly	

# Chapter 5 Maintenance

## 5.1 Routine Maintain

To make sure UPS work normal, appropriate maintenance should be schedule periodically, below items should be checked:

### **Check UPS running status.**

If the utility power is normal, UPS should working in line mode or in battery mode. And there is no warning or fault indication.

### **Check UPS running mode switch.**

Cut off the line input to simulate the utility power interrupt, UPS should transfer to battery mode, and connect the line input, UPS return to line mode again.

### **Check UPS panel.**

Check UPS panel display if it is consistent with UPS running mode.

## 5.2 Battery maintain

Battery is a very important part in the UPS system. The life of battery affected by the environment temperature and cycling use times, high temperature and deep discharge will decrease the battery life.

The environment temperature should be between 15-25°C

If UPS are not used, it is suggested to charge the battery once every 3 months.

Normally, the battery should be discharged once every 4 to 6 months.

The battery should not be replaced individually, please get the advice from local supplier

# Chapter 6 Trouble shooting

When any trouble with UPS, please check the problem refer to the table below first. If the problem cannot be solved, please contact local supplier.

## 6.1 LED Panel Warning and Fault Information

Problem	Possible reason	Solution
1 # & 6 # led light with beep.	UPS over temperature	Make sure UPS is not overload; the environment temperature is not high; no obstacle block cooling air intake and outlet . Turn off UPS for 10 minutes and try turn on again. If fail again, please contact the distributor.
1 # & 5 # led light with beep	Ups fail	Please contact the distributor.
1 # & 4 # led light with beep	Ups fail	Please contact the distributor.
1 # & 3 # led light with beep,	UPS over charge	Charger fail, please contact the distributor.
8 # led flicker.	Line voltage or frequency is out of range.	UPS is in battery mode, please save the data and turn off the UPS to check the input voltage.
	L, N reversed or earth not connected.	Reconnect the cable.
1# & 2 # led light, with beep	Battery mode UPS overload	Check the load and remove some load to make sure UPS is not overload.
1# & 2 # & 6 # led light with beep 1 every 1s	Fan not connected or fan fail	Contact the distributor
1# & 2 # , 5 # led light with beep	UPS output short	Turn off UPS, remove all loads. Make sure no short in the load, re turn on UPS, if fail again please contact the distributor.
10 # led flicker	Battery low or not connected.	Check the battery, if connected normal or battery damaged.
1# led light , 10 # led flicker with beep 1 every 1s	UPS charger fail	Contact the distributor
Line is normal, but UPS doesn't work in line mode	UPS input	Check the input MCB before the input cable
Battery discharge time short	Battery not full	Keep UPS charging for above 10 hours.
	UPS overload	Remove some load
	Batteries are over aged	Change batteries.
UPS cannot be turned on	Not enough hold key time.	Hold turn on key at least 1 second.
	No batteries or batteries low.	Connect with the batteries, and turn on UPS without load.
	UPS fail	Contact the distributor

## 6.2 LCD Warning and Fault Code

<b>Fault Code</b>	<b>Possible reason</b>	<b>Solution</b>
10	UPS output short	Turn off UPS, remove all loads. Make sure no short in the load, re turn on UPS, if fail again please contact the distributor.
22	UPS over load Fault	Check the load and remove some load to make sure UPS is not overload.
23	UPS over temperature	Make sure UPS is not overload; the environment temperature is not high; the intake is normal. Turn off UPS for 10 minutes and try turn on again. If fail again, please contact the distributor.
57	Battery low or not connected.	Check the battery, if connected normal or battery damaged.
59	UPS over charge	Charger fail, please contact the distributor.

# Chapter 7 Specification

## 7.1 Electrical

Model item		S1K(R)	S1KS(R)	S2K (R)	S2KS (R)	S3K (R)	S3KS	S6K	S6KS	S10KS	
Rated power		1000VA/800W		2000VA/1600W		3000VA/2400W		6kVA/5.4kW		10kVA/9kW	
AC Input	Input system	Single phrase & earth ground									
	Ranged voltage	230Vac									
	Frequency	50Hz									
	Voltage range	115~300VAC±5VAC									
	Frequency range	(40~70)±0.5Hz									
	Input power factor	>0.99									
	Voltage range of bypass	115VAC×(1±5%) ~285VAC×(1±5%)									
Battery Input	Nominal Voltage	24VDC	36VDC	48VDC	72VDC	72VDC	96VDC	144VDC	192VDC	240VDC	
	Battery capacity*Quantity	12VDC*2	12VDC*3	12VDC*4	12VDC*6	12VDC*6	12VDC*8	12VDC*12	12DC*16	12VDC*20	
	Backup Time	Half loaded≥7minutes, Full loaded ≥3minutes(standard)						Half loaded≥5minutes, Full loaded ≥2minutes(standard)			
	Battery charger time	Charger to 90% battery capacity in 5 hours(standard) Dependent on the capacity of external batteries(long backup time)									
AC Output	Output system	Single phrase & earth ground									
	Output voltage	220V/230V/240Vvac±2%(Inverter output)									
	Waveform	Sine Wave THD<3%(linear load) THD<7%(nonlinear load)						Sine Wave THD<2%(linear load) THD<5%(nonlinear load)			
	Output frequency	50/60±4Hz(line mode) 50Hz±1%(battery mode)									
	Dynamic voltage transient range	<5%									
	Dynamic transient restore	< 100ms									
	Overload capability	105 ~ 125%≥ 60s,126 ~ 150%≥30s The recover point is 90%									
	Crest Ratio	3 : 1									
	Transfer time	Battery <-> Line Mode 0ms									
Communications	RS232 RS485(optional),Dry contact(optional)										
Alarm Function	AC/DC input under abnormal ,overload condition and Inverter problems										
Protection Function	AC input or output above or below the range of voltage Overload ,over temperature and short circuit protection										
Noise	<55dB(1M)										

## 7.2 Mechanical

Model	W*H*D(mm)	Net Weight(kg)	Remarks
S1K	145×220×328	8.9kg	
S1KS	145×220×328	4.2kg	
S2K	190×318×365	17.2 kg	
S2KS	190×318×365	7.9kg	
S3K	190×318×365	21.6 kg	
S3KS	190×318×365	8.3 kg	
S1KR	440×88×310	13	
S1KSR	440×88×310	7.5	
S2KR	440×88×340	11.5	Not include Bat Pack
S2KSR	440×88×340	11.5	
S3KR	440×88×340	12	Not include Bat Pack
S3KSR	440×88×340	12	
B0607	440×88×438	15.5	Bat Pack For S2KR
B0807	440×88×438	20.5	Bat Pack For S3KR
S6K	650×301×432	39.1kg	
S6KS	650×301×432	15.4kg	
S10KS	650×301×432	15.4kg	
S6KSR	438*88(2U)*500	14.6kg	
S10KSR	438*88(2U)*500	14.6kg	
B1607A	438*88(2U)*680	38kG	Bat Pack For S6KR
B1607B	438*132(3U)*500	39kG	Bat Pack For S6KR

## 7.3 Environmental

ITEM	Normal range
Ambient temperature	- 10℃~ +40℃
Environment humidity	0~90%,no condensation
Altitude	Lower than 1000M: no derating Over 1000m :1% derating for every 100M rise
Storage temperature	-15℃~+45℃

## 7.4 EMC & Safety Regulation

ITEM	Standard	Level
ESD	IEC61000-4-2	LEVEL4
RS	IEC61000-4-3	LEVEL3
EFT	IEC61000-4-4	LEVEL4
SURGE	IEC61000-4-5	LEVEL4
Safety	GB4943-2001 IEC62040-1	CE

# Warranty

Products to be offered warranty from the date of purchase within the warranty period.

To obtain service under warranty via an valid guarantee offered by dealers;

To obtain service under warranty via serial number.

In case of UPS fault, please contact local service center and dealer. The transportation charges shall be borne by the buyer.

As a user, any problem you have the following service:

- Online Service via email or website
- Local distributor replace or repair service

This limited warranty does not apply to conditions as follows:

- Damage or loss resulted from force majeure or external causes;
- Warranty period expired;
- The product serial number is missed or modified;
- Disassemble or modifications to the product without authorization;
- Man-made damage