

Multiple Speed Control

You may control the VFD to drive the motor forward/reverse/stop, and at several predetermined speed, the function can be implement via control switches by following steps:

Step 1. Find the control terminal by opening button cover



Fig.1 Find control input terminal X1,X2...X5 & COM under the bottom cover

Step2. Wiring

Recommend to connect the normal open(N.O.)button switch to the control terminals as follow

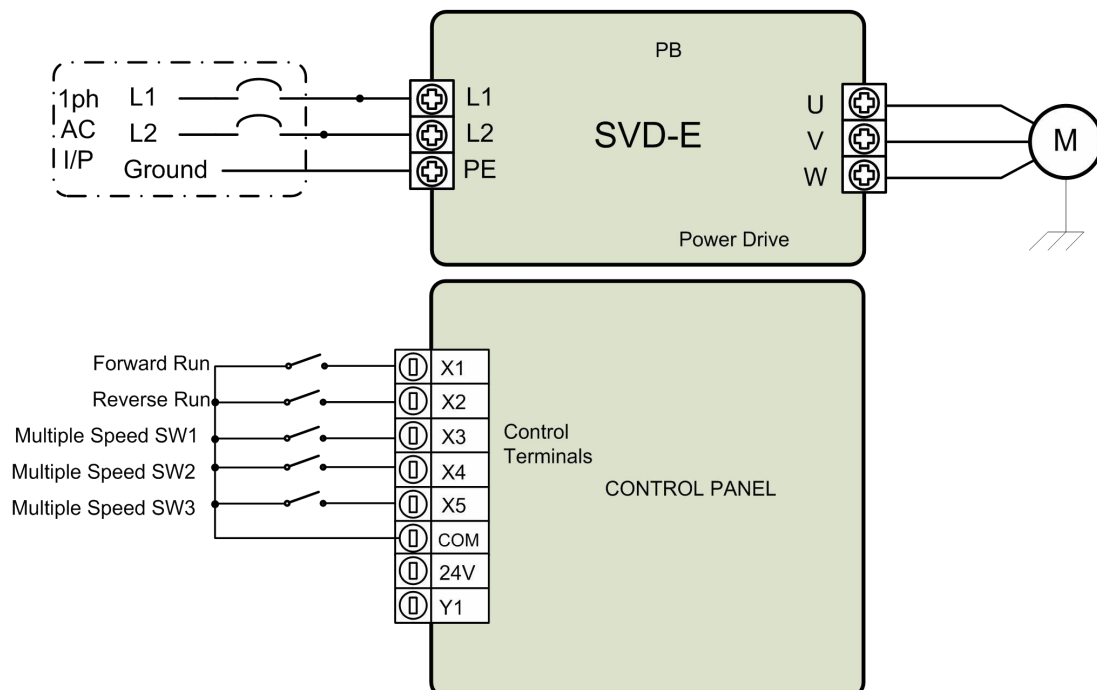

Fig.2 Wiring Diagram

Step 3. Set the function code as follow:**3.1. Select control source**

P0.01 = 5 Select Multiple speed control terminal as Frequency instruction source

P0.02 = 1 to select control terminals as running instruction source .

3.2 Define control terminal logic

P3.01 = 1 X1 used as Forward run control terminal

P3.02 = 2 X2 used as Reverse run control terminal

P3.03 = 12 X3 used as Multi-speed control SW1

P3.04 = 13 X4 used as Multi-speed control SW2

P3.05 = 14 X5 used as Multi-speed control SW3

3.3 Select operating mode

P3.07 = 0 2-line control mode #1

3.4 Set Speed of each level in function code group P8

P8.00 = 1 Select control terminal to control running and direction

Set speed of each level in P8.01~P8.07 , please notice that the number set in P8.01~P8.07 is in percentage % with referring to rated frequency set in P0.13\P0.14\PB.03, for example, if the rated frequency set in P0.13\P0.14\PB.03 is 60Hz, and P8.01 = 20, then when the speed selecting switches status are all open(speed 0 is selected), Speed is $60\text{Hz} \times 20\% = 12\text{Hz}$.

The speed selecting switch status form a binary code indexing to 8 different speed level

Function code	Speed Setting	Selecting Switch			Index
		SW3(X5)	SW2(X4)	SW1(X3)	
P8.01	Speed 0	Open	Open	Open	000
P8.02	Speed 1	Open	Open	Close	001
P8.03	Speed 2	Open	Close	Open	010
P8.04	Speed 3	Open	Close	Close	011
P8.05	Speed 4	Close	Open	Open	100
P8.06	Speed 5	Close	Open	Close	101
P8.07	Speed 6	Close	Close	Open	110
PC-08	Speed 7	Close	Close	Close	111

Below logic you can achieve by above wiring and setting

X1 Button 1 (N.O.)	X2 Button 2 (N.O.)	Multi-Speed SW1 (X5)	Multi-Speed SW1 (X4)	Multi-Speed SW1 (X3)	Status	Speed
Open	Open	Open	Open	Open	STOP	
Close	Open	Open	Open	Open	Forward Run	Speed 0 (000)
		Open	Open	Close		Speed 1 (001)
		Open	Close	Close		Speed 2 (010)
		Open	Close	Close		Speed 3 (011)
		Close	Open	Open		Speed 4 (100)
		Close	Open	Close		Speed 5 (101)
		Close	Close	Open		Speed 6 (110)
		Close	Close	Close		Speed 7 (111)
Open	Close	Open	Open	Open	Reverse Run	Speed 0 (000)
		Open	Open	Close		Speed 1 (001)
		Open	Close	Close		Speed 2 (010)
		Open	Close	Close		Speed 3 (011)
		Close	Open	Open		Speed 4 (100)
		Close	Open	Close		Speed 5 (101)
		Close	Close	Open		Speed 6 (110)
		Close	Close	Close		Speed 7 (111)

Tab.1 Control logic

As an example . An application expect to have:

1. Full speed forward
2. Full speed reverse
3. Half speed forward
4. Half speed reverse

Proposal Solution:

A. Wiring:

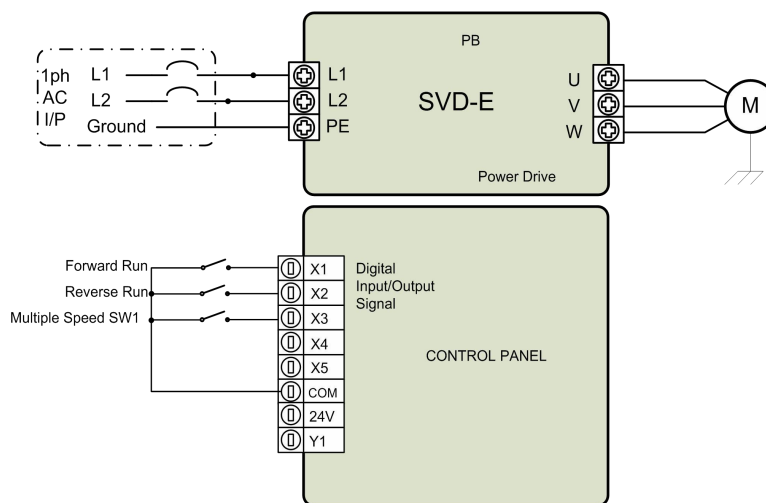

Fig.3 Wiring for Example 1

B. Function code setting:

i . Frequency and Instruction Source

- P0.01 = 5 Select Multiple speed control terminal as Frequency instruction source
- P0.02 = 1 to select control terminals as running instruction source .

ii. Define control terminal logic

- P3.01 = 1 X1 used as Forward run control terminal
- P3.02 = 2 X2 used as Reverse run control terminal
- P3.03 = 12 X3 used as speed control SW1

iii. Set Speed level

- P8.00 = 1 Control terminal control running direction
- P8.01 = 100 When SW3 is open , the speed will be 100% of rated speed (Full Speed)
- P8.02 = 50 When SW3 is close, the Speed will be 50% of rated speed (Half Speed)

You can have below switch function and behavior

SW-FWD X1 (N.O.)	SW-REV X2 (N.O.)	Speed SW1 (X3)	Speed and Direction
Open	Open	Open	STOP
Close	Open	Open	Full speed FWD
Open	Close	Open	Full speed REV
Close	Open	Close	Half speed FWD
Open	Close	Close	Half speed REV

Hopefully helps , feel free to contact us if anything else we can help . Enjoy!